

Cylindrical Shells Example

Find the volume of the solid obtained by rotating the region bounded by $x = 4 - y^2$ and $x = 8 - 2y^2$ about $y = 5$.

Solution. The region bounded by $x = 4 - y^2$ and $x = 8 - 2y^2$ is sketched below. Note that the two parabolas meet when $4 - y^2 = 8 - 2y^2$ or $y^2 = 4$ or $y = \pm 2$. The corresponding $x = 4 - (\pm 2)^2 = 0$. So, the two parabolas meet at $(0, \pm 2)$. Consider the thin slice in the figure on the right. It runs horizontally from $(4 - y^2, y)$ to $(8 - 2y^2, y)$ and has width dy . When this slice is rotated about $y = 5$, it sweeps out a cylindrical shell, as illustrated in the figure on the left. A radius for the shell is shown in the figure on the right. It is the vertical line half way along the thin slice. The y -coordinate of

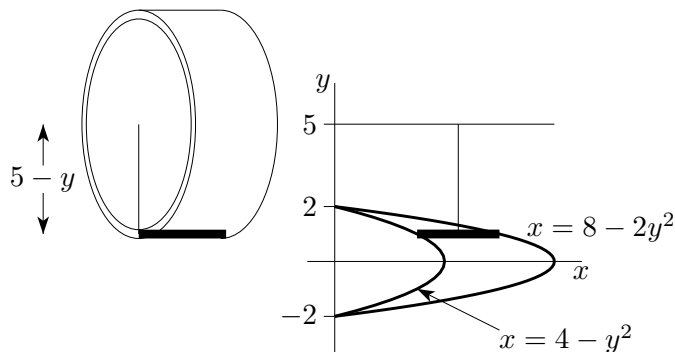

the top end of the radius is 5 and the y -coordinate of the bottom end is y . So the radius has length $5 - y$. The height of the shell is the difference between the x -coordinates at the right and left hand ends of the thin slice. So the height of the shell is $(8 - 2y^2) - (4 - y^2) = 4 - y^2$. The thickness of the shell is dy and its volume is $2\pi(5 - y)(4 - y^2)dy$. The total volume of the solid is

$$\int_{-2}^2 2\pi(5 - y)(4 - y^2)dy = 2\pi \int_{-2}^2 (20 - 4y - 5y^2 + y^3) dy$$

For any **odd power** y^n of y , and any a , the integral $\int_{-a}^a y^n dy = 0$. This is because the area with $-a \leq y \leq 0$ has the same magnitude but opposite sign as the area with $0 \leq y \leq a$. See the figure on the left below. Thus the integrals $\int_{-2}^2 y dy = \int_{-2}^2 y^3 dy = 0$. For any **even power** y^n of

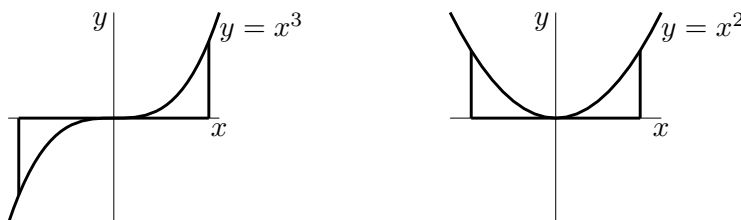

y , and any a , the integral $\int_{-a}^a y^n dy = 2 \int_0^a y^n dy$. This is because the area with $-a \leq y \leq 0$ has the same magnitude and same sign as the area with $0 \leq y \leq a$. See the figure on the right above.

The volume of the solid is

$$\begin{aligned} 2\pi \int_{-2}^2 (20 - 4y - 5y^2 + y^3) dy &= 2\pi \int_{-2}^2 (20 - 5y^2) dy = 4\pi \int_0^2 (20 - 5y^2) dy \\ &= 20\pi \int_0^2 (4 - y^2) dy = 20\pi \left[4y - \frac{1}{3}y^3 \right]_0^2 = 20\pi \left[8 - \frac{8}{3} \right] = \boxed{\frac{320}{3}\pi} \end{aligned}$$